

I/341e

**BIZERBA | BASIC SYSTEM**

# BS 200 F-E / BS 200 F-T



CE  
SC  
BS  
ES  
BC  
CS  
EC

→ COMPACT ELECTRONIC SYSTEM SCALE WITH CUSTOMER RECEIPT OR LABEL PRINTER.

→ BS 200 F-T





# HOW DO YOU BENEFIT FROM **MAXIMUM PERFORMANCE IN A COMPACT FORMAT?**

## → Small and perfectly formed

The Bizerba BS 200 is the ideal entry model for a System scale. With its extremely compact construction it is particularly suitable wherever there is a need for safe weighing but little space. The BS 200s interfaces allow you to build a networked system – without additional equipment – of up to 15 scales. It can also link to a PC or the Bizerba product management system WinCWS®, or connect to two cash drawers (optional).

## → Application

The BS 200 can be used in all fresh food areas: At the deli counter, in self-service areas or for labelling. Note in particular its practical features with check-out functions such as paying in/out function and currency conversion.

## → First rate technology

Depending on the model the BS 200 is equipped with either a robust thermal receipt or label printer, which will print all label and receipt data clearly and reliably and according to your specifications.

The BS 200 has 1 MB RAM memory available for approx. 1000 PLU, the RAM memory can be extended up to 6 MB (optional).

The scale program is stored in Flash-RAMs and can therefore be updated via PCs at any time. This eliminates the need for the time consuming exchange of individual EPROMs.

The freely programmable keyboard can be adapted to your precise requirements.

The backlit LCD display provides clear information with up to 20 digits of product text.

## → Reporting

Alongside PLU's the BS 200 will issue reports about product sub-groups and main product groups, vendors, VAT, department and main department.

## → Easy cleaning

The smooth housing and sealed, wear-resistant tactile keyboard facilitate effortless daily cleaning of the scale.

Thorough cleaning is made easy by the thermal printhead, which simply swings aside.

## → Additional options

Writeable Silicon front foil

Frame with 24 self service keys

→ BS-Scale-  
Network



→ Cash drawer

→ EDP

## → BS 200 F WITH CASH DRAWER



\*\* WITH THE BIZERBA SYSTEM SCALE BS 200.

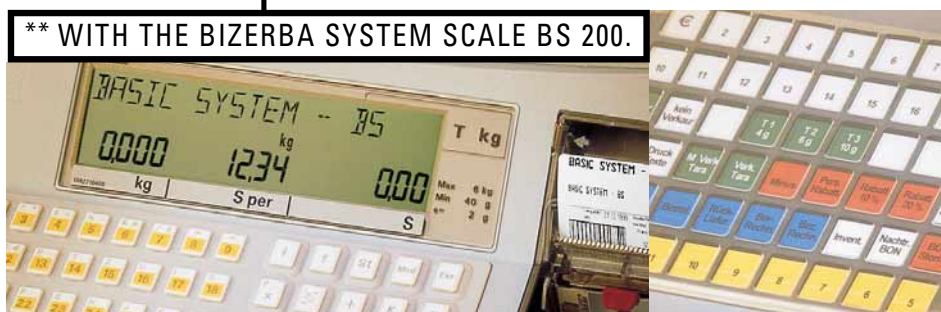



## KEY TECHNICAL SPECIFICATIONS



- **Weighing range:** 6 15 30 3/6<sup>1)</sup> 6/15<sup>1)</sup>15/30<sup>1)</sup> 15lb 30lb
- **Division:** 2 5 10 1/2 2/5 5/10 -0.01-0.01
- **Minimum load:** 40 100 200 20 40 100 0.2 0.2
- **Maximum tare load:** -6 -15 -30 -6 -15 -30 15lb 30lb  
Automatic scale zero, zero key programmable, printout below minimum weight depending on country-specific calibrating regulations.
- **Display:** 7-/14-segment, backlit LC display  
Number of characters for product text: 15/20,  
Weight display: 5 digits, Basic price display: 6 digits,  
Selling price display: 7 digits, tare display: 4 digits.
- **Keyboard:** Tactile keyboard, 84 freely programmable keys including: 30 function keys and 54 direct keys for PLU and other functions, can be individually labelled (optional), add-on frame with 24 self service keys can be mounted on operating keyboard (optional).
- **Programmable data per PLU:** Basic/unit price, product description up to 500 characters, additional text up to 2000 characters, product group, sell-by-date, barcode, price overwrite, tare, VAT-rate, By Count (= units), fixed weight, price per kg, 100 g, lb, 1/2 lb, 1/4 lb, graduated price, special offer price, special offer text, timed campaigns, 3 price groups.
- **Memory:** 16-Bit-processor, standard memory of 1MB for 1000 PLU<sup>2)</sup>, with basic price and 29-digit product text, upgradable to 6 MB (optional), for 32000 PLU. Up to 999 product groups, 99 main product groups, 99 departments, 99 main departments, each with 20-digit text, 99 different moving promotional texts with 500 characters each, 256 vendors.
- **Thermal receipt printer (BS 200 F-T):** 432 dots, resolution 8 Dot/mm, print width 54mm (2,1"), receipt width 58mm (2,3"), speed 53mm/s (2"), inverted printing, upper-case or lower-case letters, EAN-/UPC barcode, 9 font sizes, optional Talon.
- **Thermal label printer (BS 200 F-E):** As receipt printer, label width 58mm (2,3"), max. label length 200mm (7,9"), labels freely configurable, 2 print directions, different label sizes, switching to adhesive labels and receipt printing.
- **Interfaces:** Network (RS 485) with up to 15 scales, one serial interface (RS 232), licensed interface protocol for connection to EDP, control of up to two cash drawers (optional).
- **Dimensions in mm (inches):**

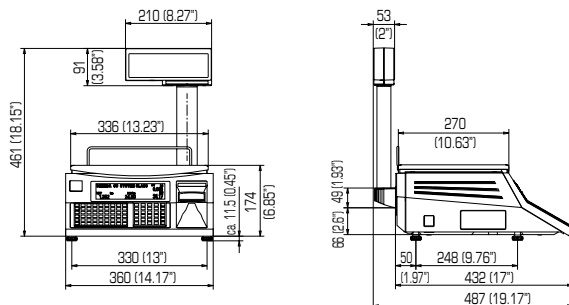

### → Reports/Analyses:

Number of sales periods: freely configurable (max. 4) for PLU, product groups, main product groups, VAT, vendors, department, main department, training, various sorting criteria, price modification journal, article modification journal, electronic receipt journal. In combination with licensed software: cash and cashier.

### → Further features:

Ticket voiding, scroll function with voiding, Pay-in/Pay-out mode, currency conversion, 20 footer/header lines on receipt, vendor tare, receipt repeat, recall of last receipt total, menus.  
Labelling modes: Weight and fixed price, quantity preselection for automatic print-out, separate turnover reports, scale program loadable via interface, self and quick service, various tare options, menu password protected.

### → Licensed software:

Interface protocols, check-out functions, electronic-cash, delivery note, meat traceability proof, scanning

### → Working temperature range:

-10° to +40°C/14°F to 104°F

### → Operating (Mains) voltage:

(-10 + 6%) 230V or (-15 + 10%) 120V

### → Power consumption:

At 230V min. 125mA / max. 220mA,  
At 120V min. 240mA / max. 440mA

### → Mains frequency:

50 / 60Hz

### → Examples for receipts and labels:

**BIZERBA BASIC SYSTEM - BS**

Dept. 1      POS 1      # 000015  
31.03.2002 10:48:56      5/1      Uen. 4

kg	€/kg	€
<b>BANANAS</b>		
FULL OF GOODNESS		
0.160	0.85	0.14
<b>APPLES BRAEBURN</b>		
LOOSE VERY CRISP		
0.660	0.39	0.26
<b>2 items Total</b>		<b>€ 0.40</b>

Amount tend.  
Change  
31.03.2002 10:49:04C  
**THANK-YOU FOR YOU WE TICK**

---

**BIZERBA BASIC SYSTEM - BS**

**SPECIALITY HOMEMADE LINCOLNSHIRE SAUSAGE**

INGREDIENTS:  
65% MINIMUM MEAT, PRESERVATIVES,  
FLAVOUR ENHANCER,

Packed 02.03.2002      Use-by: 30.03.2002

€ /kg	Net weight
4.14	1.516 kg
<b>€ 6.28</b>	

12100001 10062801

1) Optional

2) The number of PLUs depends on the configuration of the data storage with other functions, the memory capacity can be upgraded in stages (optional) in order to adapt to requirements.



# BIZERBA

\_balanced information